

- Single quick-actuation for the rapid opening and closing
- Fully sealed

Workpiece Positioning System



Application/customer benefits

- Huge reduction of set-up times for highest efficiency
- Safe workpiece clamping with maximum holding forces and highest repeatability
- Ideal for 5-axis machining
- Central quick actuation (270° rotation)
- Flexible configurations for customized use
- Interchangeable to the zero point system WPS by using flange module

Technical features

- Diameter 80/40 mm, Height 40 mm
- Pull-in force 2.5 kN
- Max. torque 10 Nm
- Repeatability < 0.005 mm
- Holding force 25 kN (mounting screw M10 - 12.9)
- **proofline®** = fully sealed - low maintenance

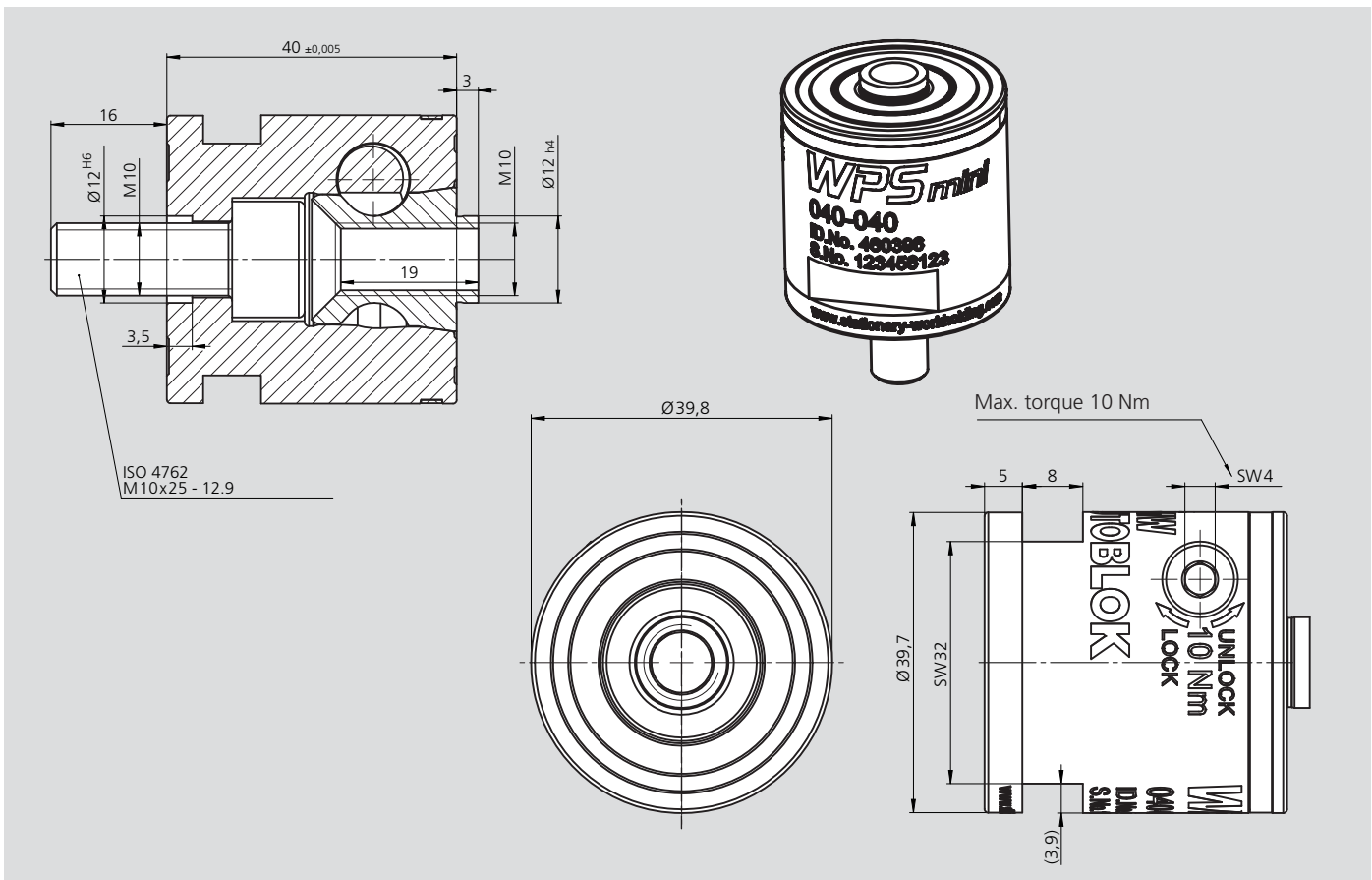

Technical data

| SMW-AUTOBLOK Type | WPS Mini 040-040 460396 |
|---------------------------------------|----------------------------|
| Pull-in force (kN) | 2,5 |
| Repeatability (mm) | < 0.005 |
| Holding force (kN) (clamping pin M10) | 25 |